

IAHT

Auto-Indexing Chuck



SPECIAL CHUCK

- Machine multiple surfaces in a single clamping
- On-the-fly indexing
- Index positions 3 x 120° or 6 x 60°
- Accurate, durable indexing system

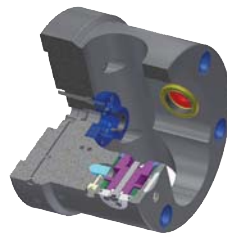

Work Piece

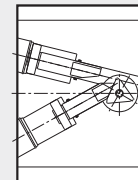
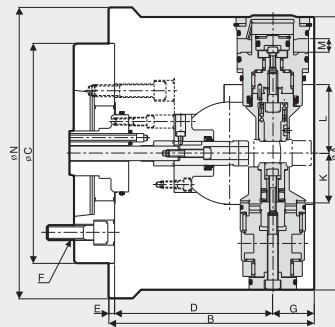
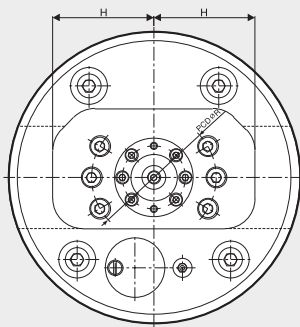

60° INDEXING

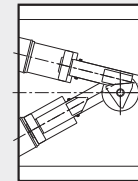

120° INDEXING

Dimensions

	ΦA	B	ΦC(h7)	D	E	F	G	H	K	L	M	ΦN	ΦR
IAHT-230	230	158	130	123	15	M10	35	102	40	58	14.5	245	104.8
IAHT-280	280	193.5	170	143.5	11	M16	50	82.5	56	71	21	295	130
IAHT-300	300	200	170	143.5	11	M16	56.5	82.5	56	65	25	295	130

Specifications

Type	Clamp Piston Area	Main Spindle Bore	Max. Speed	Weight	GD ²
	[cm ²]	[mm]	[r.p.m.]	[kg]	[kgf.m ²]
IAHT-230	1270	OVER 45	2400	35	1.3
IAHT-280	2170		2000	65	3.6
IAHT-300	3500		1800	83	4.2